

Grubenbreite Largeur de la fosse	B2 = 2280
Grubentiefe Profondeur de la fosse	T2 = 2410
Rampenhöhe Hauteur du quai	RH = 1200
unterfahrbare Höhe Hauteur pour passer au-dessous	UFH =
Torbreite Largeur de la porte	TB = 2800
Torhöhe Hauteur de la porte	TH = 3200

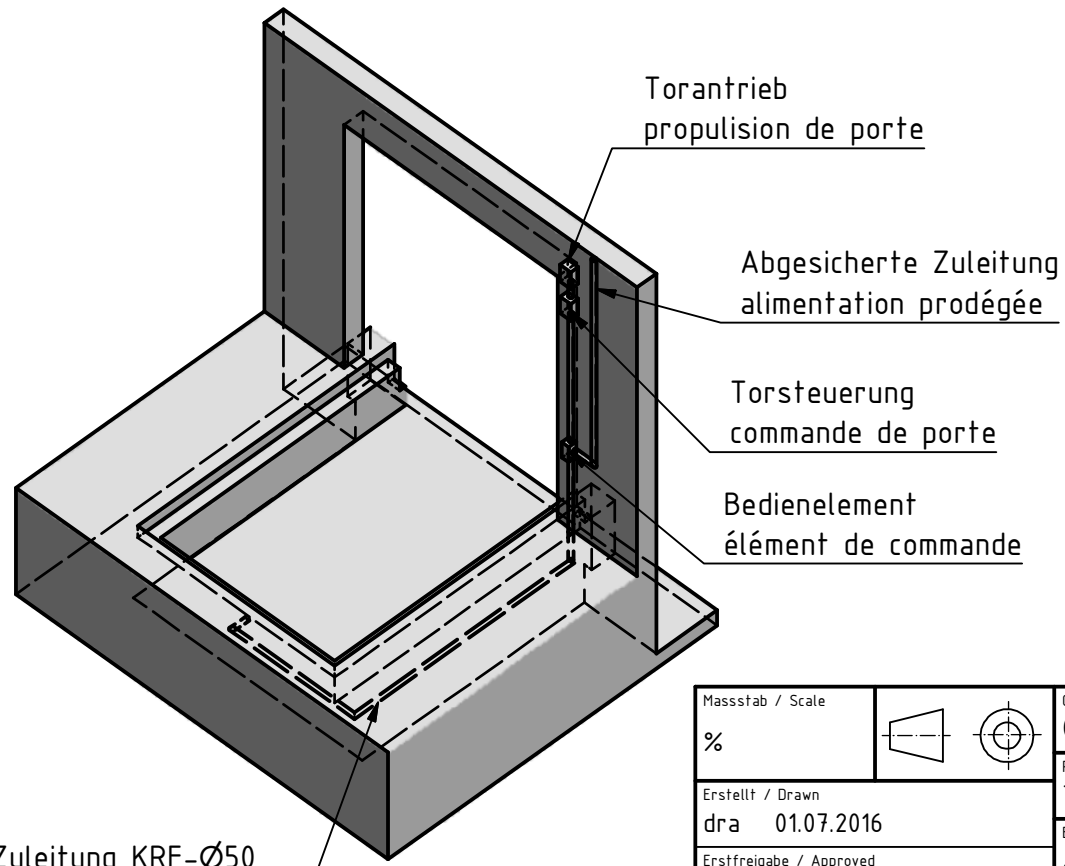
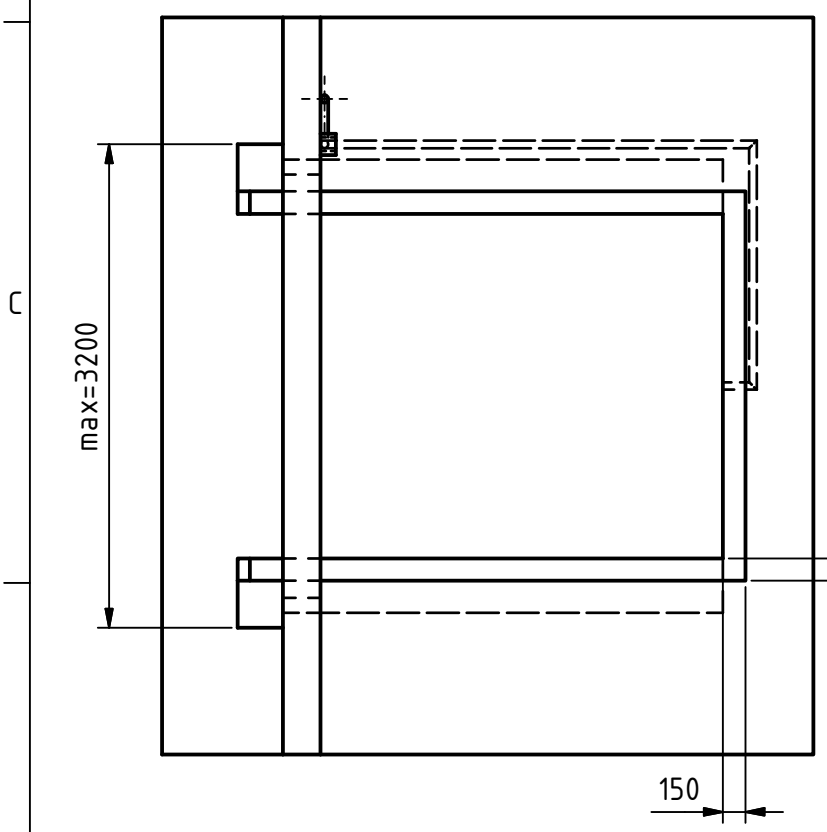

VR- Masstabelle				
Typ-Code	VR-Breite	VR-Tiefe	B2	T2
VR 1919-	1900	1900	1980	1910
VR 1924-	1900	2400	1980	2410
VR 2224-	2200	2400	2280	2410
VR 2424-	2400	2400	2480	2410
VR 2230	2200	3000	2280	3010
VR 2240-	2200	4000	2280	4010
VR 2250-	2200	5000	2280	5010

Alle Masse in mm, alles Fertigmasse  
toutes les dimensions en mm, dimensions finales

Mass, Lot- und Diagonalabweichung max +/-5mm  
dimensions en diagonales avec fil à plomp +/-5mm

Massstab / Scale %		Gewicht / Mass 0.000 kg		
Erstellt / Drawn dra 01.07.2016		Produkttyp / Producttyp 720 Verladerrampen / Hebebühnen	Ursprung / Origin	
Erstfreigabe / Approved Jobprocessor 01.07.2016		Beschreibung / Title VR Aussparungsplan	Ersatz für / Replacement for	Blatt-Nr. / Page no. 1 / 1
		Dimension VR mit Innentor	Artikel-Nr. / Article code 270.700.0102	
			Zeichnungs-Nr. / Drawing no. S-236039	Revision 04
© Gilgen Logistics				